

SPECIFICATION FOR APPROVAL

REF. :

PROD. NAME	SMD Power Inductor	ABC'S DWG NO.	SR0603□□□□L□-□□□		
		REV.	20150507-G	PAGE	1

I . Configuration and dimensions :

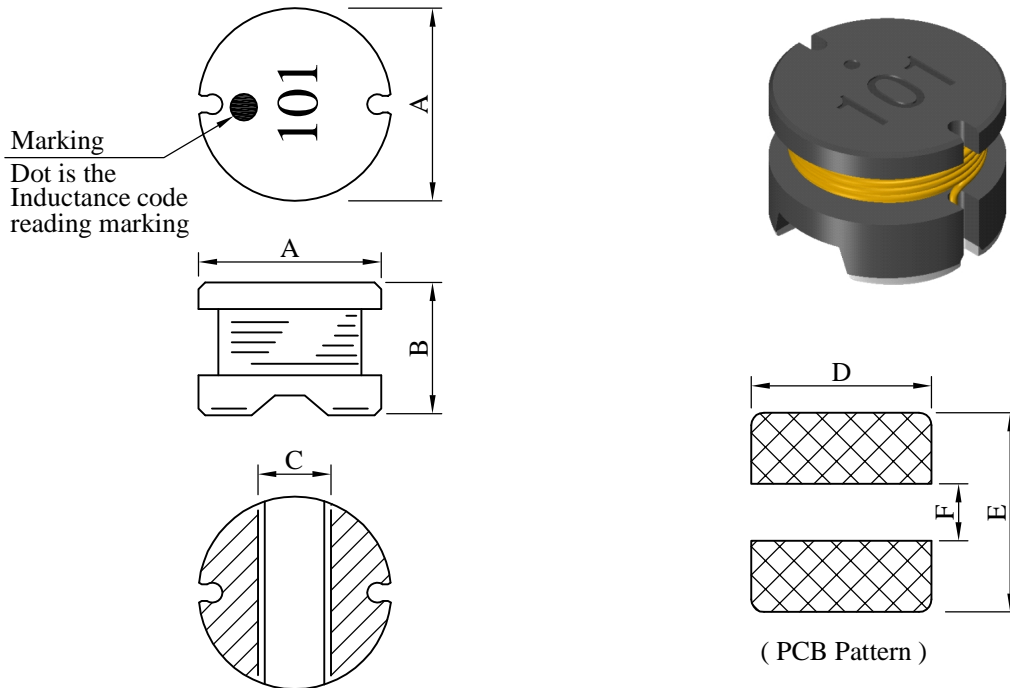

Unit : m/m

A	B	C	D	E	F
5.60 ±0.2	3.70 ±0.3	2.30 ref.	5.80 ref.	6.00 ref.	1.70 ref.

II . Description :

- a . Ferrite drum core construction.
- b . Enamelled copper wire : H class
- c . Product weight : 0.350g (ref.)
- d . Moisture sensitivity Level 1
- e . Products comply with RoHS' requirements
- f . Halogen free available

Peak Temp : 250°C max.
Max. Peak Temp - 5°C : 30sec max.
Max time above 217°C : 60sec~150sec max.

III . General specification :

- a . Storage temp. : -40°C ----+125°C
- b . Operating temp. : -40°C ----+125°C
(Temp. rise included)
- c . Resistance to solder heat : 250°C .10 secs.

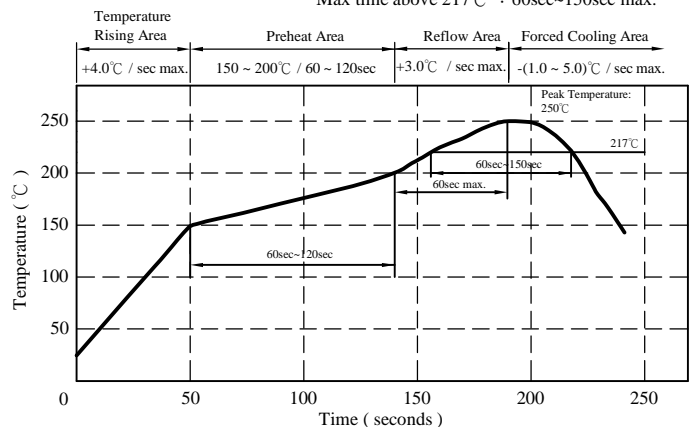

AR-001C

SPECIFICATION FOR APPROVAL

REF. :

PROD. NAME	SMD Power Inductor	ABC'S DWG NO.	SR0603□□□□L□-□□□		
		REV.	20150507-G	PAGE	2

IV . Electrical characteristics :

DWG No.	Inductance (μ H)	Q ref.	Test Freq. (Hz)		SRF (MHz) nom.	RDC (Ω) max.	IDC (A) max.
			L	Q			
SR06031R5ML□-□□□	1.5±20%	24	1k	7.960M	85.0	0.040	3.00
SR06032R5ML□-□□□	2.5±20%	21	1k	7.960M	74.0	0.045	2.35
SR06033R3ML□-□□□	3.3±20%	21	1k	7.960M	68.0	0.048	2.20
SR06033R9ML□-□□□	3.9±20%	22	1k	7.960M	62.0	0.050	2.10
SR06034R7ML□-□□□	4.7±20%	20	1k	7.960M	56.0	0.066	1.80
SR06035R0ML□-□□□	5.0±20%	19	1k	7.960M	50.0	0.070	1.60
SR06036R8ML□-□□□	6.8±20%	19	1k	7.960M	44.0	0.110	1.38
SR06037R5ML□-□□□	7.5±20%	19	1k	7.960M	38.0	0.120	1.29
SR0603100ML□-□□□	10.0±20%	24	1k	2.520M	34.0	0.150	1.14
SR0603120ML□-□□□	12.0±20%	23	1k	2.520M	30.0	0.160	1.02
SR0603150ML□-□□□	15.0±20%	22	1k	2.520M	28.0	0.180	0.93
SR0603180ML□-□□□	18.0±20%	23	1k	2.520M	24.0	0.250	0.82
SR0603220ML□-□□□	22.0±20%	20	1k	2.520M	20.0	0.275	0.75
SR0603270ML□-□□□	27.0±20%	19	1k	2.520M	19.0	0.300	0.67
SR0603330KL□-□□□	33.0±10%	23	1k	2.520M	15.0	0.450	0.61
SR0603390KL□-□□□	39.0±10%	22	1k	2.520M	13.0	0.460	0.56
SR0603470KL□-□□□	47.0±10%	20	1k	2.520M	13.0	0.550	0.52
SR0603560KL□-□□□	56.0±10%	17	1k	2.520M	12.0	0.615	0.48
SR0603680KL□-□□□	68.0±10%	17	1k	2.520M	12.0	0.720	0.44
SR0603820KL□-□□□	82.0±10%	15	1k	2.520M	11.0	0.840	0.40
SR0603101KL□-□□□	100.0±10%	28	1k	796k	9.6	0.950	0.38
SR0603121KL□-□□□	120.0±10%	27	1k	796k	8.1	1.100	0.36
SR0603151KL□-□□□	150.0±10%	28	1k	796k	7.5	1.430	0.32
SR0603181KL□-□□□	180.0±10%	26	1k	796k	6.9	1.600	0.30
SR0603221KL□-□□□	220.0±10%	26	1k	796k	5.5	2.000	0.26
SR0603271KL□-□□□	270.0±10%	26	1k	796k	4.9	2.400	0.24
SR0603331KL□-□□□	330.0±10%	28	1k	796k	4.7	3.200	0.20
SR0603391KL□-□□□	390.0±10%	28	1k	796k	4.1	3.400	0.18
SR0603471KL□-□□□	470.0±10%	29	1k	796k	3.5	4.550	0.15

- 1). □ : Packaging information : □ Code
 2). "-□□□" : Reference code
 3). Electrical specifications at 25°C

- 5). IDC base on Temp. rise 40°C max.
 & Δ L/L0A=10% max.

AR-001C



SPECIFICATION FOR APPROVAL

REF. :

PROD. NAME	SMD Power Inductor	ABC'S DWG NO.	SR0603□□□□L□-□□□		
		REV.	20150507-G	PAGE	3

V . Curve :

SR06031R5ML□

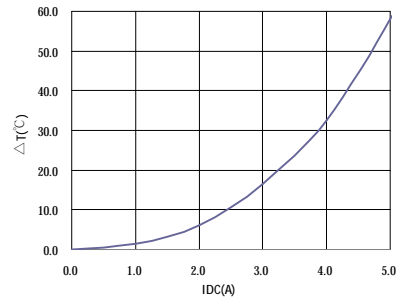
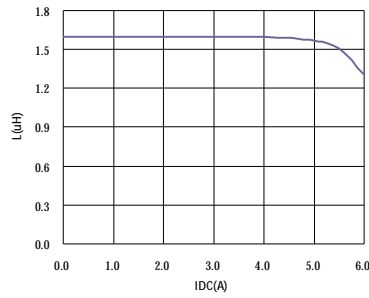

SR0603100ML□

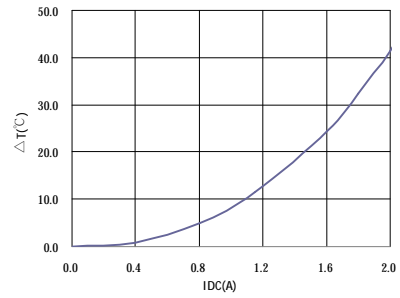
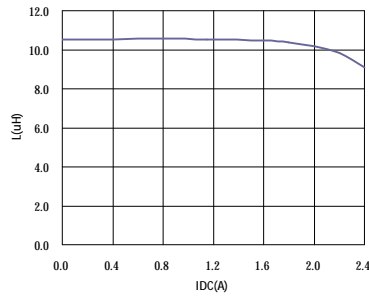

SR0603101KL□

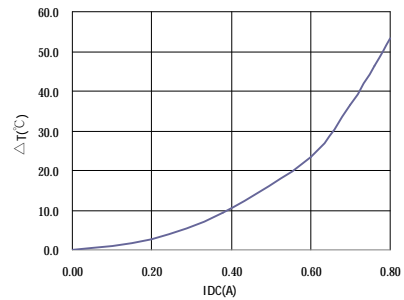
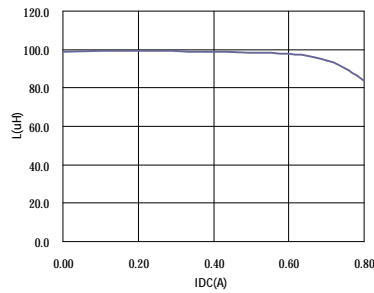

SR0603471KL□

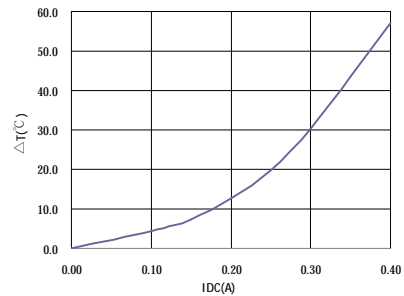
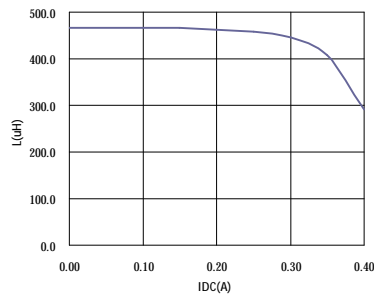

AR-001C

SPECIFICATION FOR APPROVAL

REF. :

PROD. NAME	SMD Power Inductor	ABC'S DWG NO.	SR0603□□□□L□-□□□		
		REV.	20150507-G	PAGE	4

VI . Packaging information :

(1) Configuration

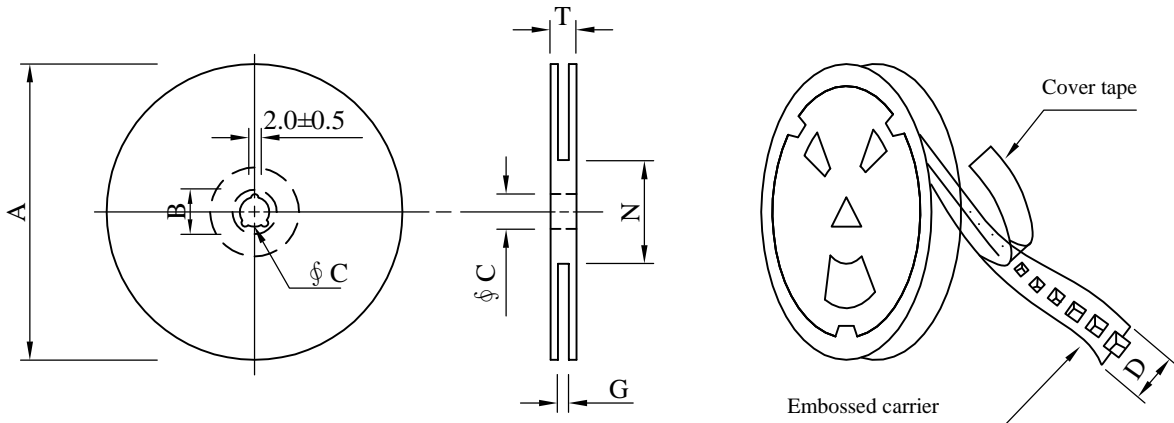

※Carrier tape width : D

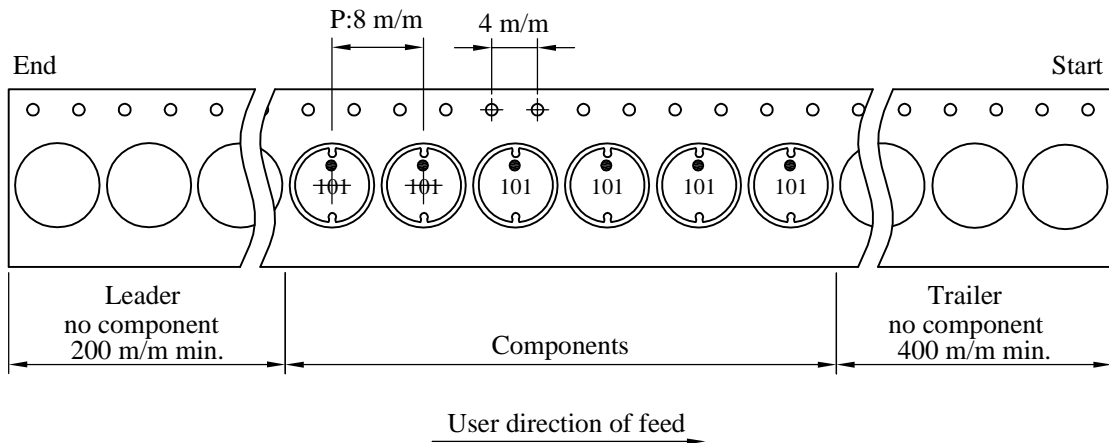

(2) Dimensions

Unit:m/m

Style	A	B	C	D	G	N	T
07 - 12	178	21±0.8	13	12	14 ⁺⁰	50 ⁻⁰	16.5
13 - 12	330	21±0.8	13±0.5	12	14 ⁺⁰	50 ⁻⁰	18.4

(3) Q'TY & G.W. Per package

Code	Inner : Reel			Outer : Carton		
	Q'TY (pcs)	G.W. (gw)	Style	Q'TY (pcs)	G.W. (Kg)	Size (cm)
B	400	240	07 - 12	16,000	11.0	42 x 41 x 24
C	1,500	880	13 - 12	12,000	8.3	38 x 37 x 22

AR-001C

SPECIFICATION FOR APPROVAL

REF. :

PROD. NAME	SMD Power Inductor	ABC'S DWG NO.	SR0603□□□□L□-□□□		
		REV.	20150507-G	PAGE	5

VII . Reliability test :

Item	Reference documents	Test Condition	Test Specification
1.High Temperature Exposure	MIL-STD-202 Method 108	1.Temperature: 125±2℃ 2.Time:96±2 hours.	1.No mechanical or electrical damage. 2.Inductance shall not change more than ±10%.
2.Temperature Cycling	JESD22-A 104	1.Temperature: -40℃ ~ +125℃ 2.Number of cycle:100 cycle 3.Dwell time:30 minutes	1.No mechanical or electrical damage. 2.Inductance shall not change more than ±10%.
3.Biased Humidity Test	MIL-STD-202 Method 103	1.Temperature : 85±2 ℃ 2.Humidity: 85% RH. 3.Time:96±2 Hours	1.No mechanical or electrical damage. 2.Inductance shall not change more than ±10%.
4.Operational Life	JESD22-A 108	1.Temperature: 125℃ (Temp. rise included) 2.Time:96±2 hours. 3.Rated current	1.No mechanical or electrical damage. 2.Inductance shall not change more than ±10%.
5.External Visual	JESD22-B 101 & MIL-STD-883 Method 2009	Inspect product constructions, marking and workmanship.	1.No pollution on the surface of products. 2.Clear marking. 3.No crack.
6.Physical Dimensions	JESD22-B 100	Verify physical dimensions to the applicable product detail specification.	Per product specification standard
7.Resistance to solvents	MIL-STD-202 Method 215	Immerse into solvent for 3±0.5 minutes & brush 10 times for 3 cycles.	1.No body change in apperance. 2.No marking blurred. 3.Inductance shall not change more than ±10%.
8.Vibration Test	MIL-STD-202 Method 204	1.Frequency and Amplitud : 10-2000-10 Hz, 1.5 mm. 2.Direction:X, Y, Z 3.Test duration:2 hours for each direction, 6 hours in total.	1.No mechanical or electrical damage. 2.Inductance shall not change more than ±10%.
9.Resistance To Soldering Heat Test	MIL-STD-202 Method 210 & J-STD020D.1	1.Highest temperature : 250±5℃. 2.Time (temp. ≥ 217℃) : 60~150 Second. 3.IR reflow times : 3 times.	1.No mechanical or electrical damage. 2.Inductance shall not change more than ±10%.
10.Saturation Current	JIS C 6436 & User SPEC.	1.Applied rated current for 5 second. 2.Saturation current	Inductance shall not drop more than 10% max.
11.Over load	JIS C 6436 & User SPEC.	1.Applied one and half rated current for a period of 5 minutes. 2.Rated current	No electrical or mechanical damage
12.Temperature Rise Current	JIS C 6436 & User SPEC.	1.Applied rated current for 10 minutes. 2.Temperature measure by digital surface thermometer. 3.Irms current	Surface temperature rise is less than 40℃ max.
13.Solderability Test	J-STD-002 & JESD22-B 102	1.Baking in pre-testing : 150±5℃ / 16Hours±30 min. 2.Peak temperature : 240±5℃ 3.Time (temp. ≥ 217℃) : 60~150 second. 4.IR reflow times : 1 times.	More than 95% soldering coverage min on terminations.
14.Electrical Characteriazation	MIL-STD-202 Method 304 & User SPEC.	1.Operating temperature : -40℃~125℃ 2.Room temperature : 25℃.	1.No mechanical or electrical damage. 2.Inductance shall not change more than ±10%.
15.Drop	CNS-C6354 & GB/T 2423.8	1.Products shall be mounted on SPEC. pcb and dropped down from a heigh of 1m 2.Drop total time : 6 time (Every side ofsample drop 2 time)	1. Adhesion on PCB shall be enough. 2. Product appearance shall not break. 3. No electrical damage.
16.Terminal Strength Test	IEC 60068-2-21	1.Apply push force to samples mounted on PCB. 2.Force of 1.8 kg for 60±1 seconds.	After test, inductors shall be no mechanical damage.

AR-001C